

Set-Up Sheet Elcon Cleon

Driver:
 Date:
 Location:
 Test / Free Training / Qualification Heat / Sub Final / Final

Track Conditions: Dry / Damp / Wet
 Track surface:
 Avg lap time: sec

Engine: 26 / 23 CC
 Air temp.: °C
 Weather: Sunny / Cloudy / Rain
 Result:

FRONT:

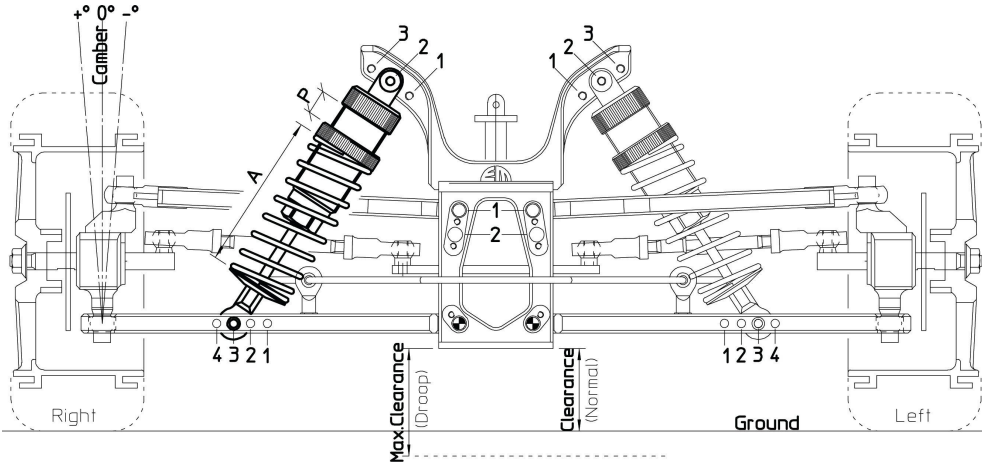
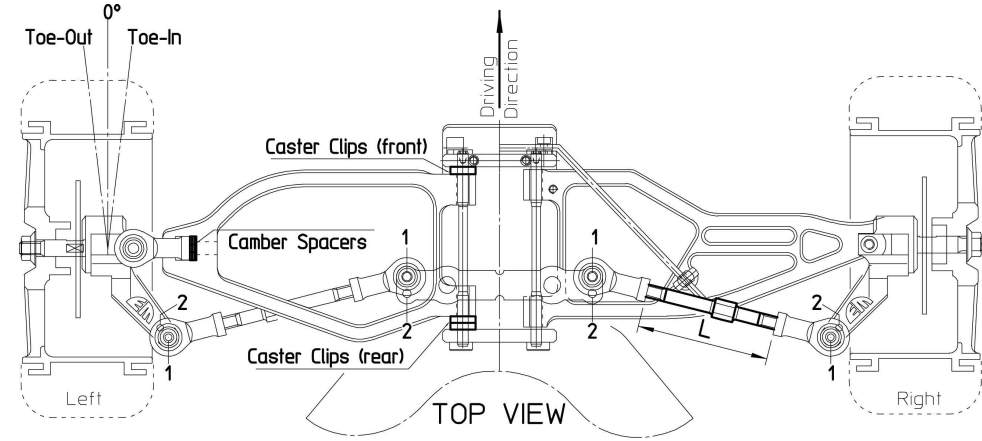

Tyres:
 Compound: S / M / H
 Status: new / used / old

Caster
 Clips front: 1 / 2 / 3
 Clips rear: 1 / 2 / 3

Camber
 Spacers: 1 2 3 4 5

Toe-In / Toe-Out:[°]

Stabilisation bar: 2.5 / 3.0 [mm]

Shock absorber piston size [mm]:
 2.0 2.1 2.2 2.3 2.4 2.5 2.6 2.7

Shock absorber spring size [mm]:
 2.0 2.1 2.2 2.3 2.4 2.5

Spring length [A]: 100 / 107 mm
 Pre-load [P]:mm

REAR:

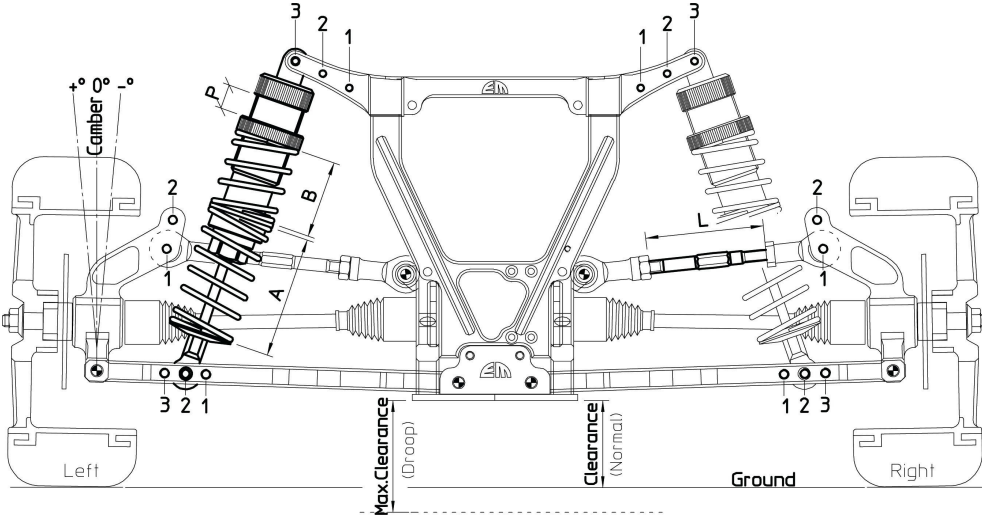

Tyres:
 Compound: S / M / H
 Status: new / used / old

Shock absorber piston size [mm]:
 2.0 2.1 2.2 2.3 2.4 2.5 2.6 2.7

Spring size A [mm]:
 2.1 2.2 2.3 2.4 2.5 2.6 2.7
 Spring length: 100 / 107 mm

Spring size B [mm]:
 2.4 2.5 2.6 2.7
 Spring length: 40 / 45 mm

Pre-load [P]:mm

Stabilisation bar: 3 / 4 [mm]

Toe-In: 3° / 4.5° / 6°

Upright shifted: forward / backwards
 Clips in front: 1 / 2 / 3 / 4

Remarks:

Gearing:
 Z1= 18 / 19 / 20
 Z2= 45 / 46
 Z3= 15 / 16 / 17
 Z4= 48 / 49